

SilverDust D2 IG (QCI-D2-IG)

The SilverDust D2 I-Grade (IG) is a servo controller/driver for QuickSilver's line of NEMA 11, 17, and 23 frame, high torque, direct drive servomotors. The IG controller/driver is open framed and designed to servo QCI's I-Grade motors through a single connector. This single cable solution allows for easy installations and simple cable routing. The second connector is the SilverLode Multi-Function Interface (SMI) port and contains the power, communications and seven 3.3V I/O.

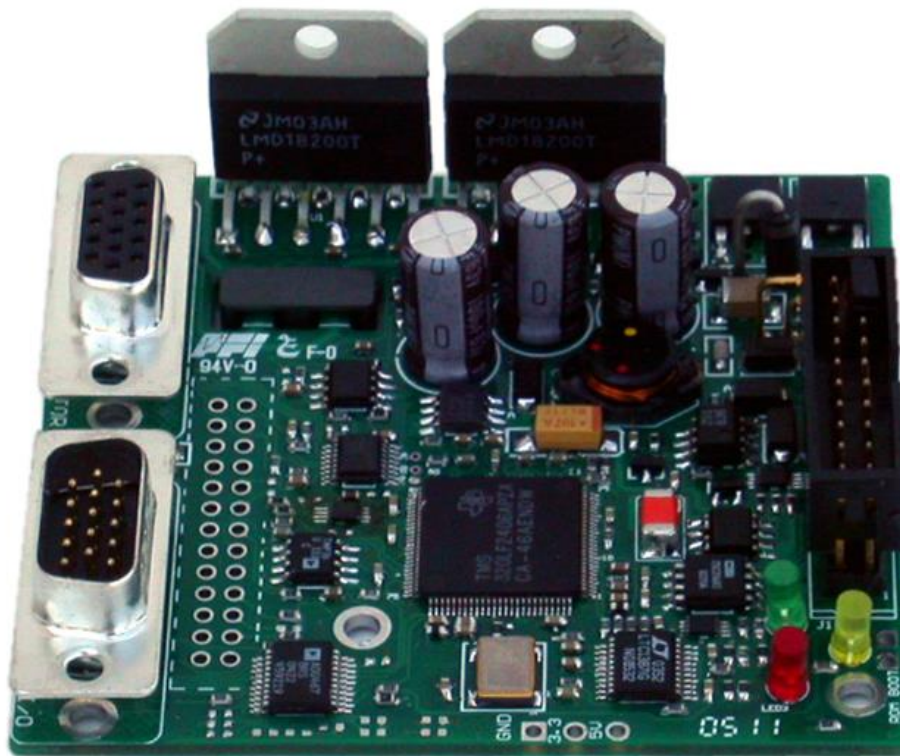

SilverDust D2 IG
QCI-D2-IG

System Overview

Point-to-Point Moves

- Relative or Absolute
- Velocity or Time Based
- S-Curve

Advanced Motion Profile Moves

- Profile Move Commands
- Register Based
 - Position/Accel/Decel/Vel
 - Modify On-the-Fly

Multi-Axis Linear Interpolation

- XYZ Coords Contained in Text File
- CANopen® used for local bus
- 1000+ Points Stored In NV Memory

Built-In Voltage Clamp

- Regenerative Braking Resistor

Input/Output

- 7 TTL Digital I/O
 - Use for QCI-BO-B52 24V I/O
- 4 Analog Inputs (Joystick)
- Analog Output Option
- Programmable Limit Switch (PLS)
 - Dynamically Sets Output
Dependent on Motor Position
- Secondary Encoder In
- Encoder Out

Program and Data Storage

- 32K Non-Volatile Memory:
- 2000-3000 Program Lines
- User Data Examples
 - CAM Tables
 - Motion Profiles
 - Lookup Tables

Electronic Slip Clutch/Brake

- Variable Torque
- Wind/Unwind Applications

Anti-Hunt™

- Optionally use Open Loop While Holding
- No Servo Dither While At Rest

Electronic Gearing/Camming

- Follow Encoder (A/B Quadrature) or Step and Direction
- Dynamic Gear Ratios
 - Integer Ratios
32767:1 to 1:32767
 - Decimal Ratios to 7 Places
- Electronic Cam
 - Import Tables From Text File
 - Over 2500 Points
 - Multiple Tables

Communications

- RS-485/RS-232 @ 230K Baud
- ASCII, Binary, Modbus®, DMX512
- Host Control While Servo in Motion
- CANopen® (optional)

Programming Language

- Easy, Menu Driven Interface
- Command Parameter Prompts
- No Syntax Errors
- User Namable I/O and Registers

Advance PVIA™ Servo Loop

- 100:1 Inertial Mismatch
- Direct Drive Oversized Inertial Loads
 - Flywheels/Belt Drives
 - Typically Without Gearheads
- More Stable Than PID

Digital 4 Quadrant Vector Drive

- DSP Driven for Reduced Noise

Multi-Task/Multi-Thread

Compatible with QCI Motor/Encoders

- NEMA 11 Frame
 - 4000 Counts/Rev Encoder
 - Up To 9 oz-in (continuous)
- NEMA 17 Frame
 - 8000 Counts/Rev Encoder
 - Up To 43 oz-in (continuous)
 - IP50 or IP65
- NEMA 23 Frame
 - 8000 Counts/Rev Encoder
 - Up To 300 oz-in (continuous)
 - IP50 or IP65

Input Power

Voltage

+12 VDC to +48 VDC, regulated. Device must be initialized for the actual operating voltage.

Over-Voltage Protection

None available. Voltages exceeding +55 VDC will permanently damage the controller/driver electronics. The IG includes an onboard clamp circuit. The bare-board configuration includes the clamp circuit, but must have an external resistor connected prior to connecting any motor. A suitable value is $V+/5$ (ohms), but not more than 10 ohms, nor less than $V+/6$ ohms. Power rating is dependent upon operation, but should be at least 10W.

Reverse Polarity Protection

Reverse polarity protection is available on the SilverDust IG. (Note, however, if power supply is not floating, connecting the V+ input to Ground will cause this potential to be present at the communications and I/O lines, which may damage these lines or that to which they are connected.

Input Current

4 Amps maximum for any input voltage, +12 VDC to +48 VDC.

Output Power

Output/Driver Current

3.5 Amps continuous per phase *; 4.5 Amps peak per phase *.

* With Adequate Heat Sink.

Maximum Output Power

150 Watts continuous power with adequate heat dissipation.

Encoder Interface

2000 Lines = 8000 counts/revolution

Designed to work with QCI's I-Grade motor/encoders. Quadrature differential signals are employed.

Inputs & Outputs

Standard I/O on all SilverDust IG IO1-IO7

Digital Inputs

0 to +3.3 VDC. LVTTTL level compatible.
Effective internal 200K ohm impedance to +3.3 V.

Digital Output Voltage

0 / +3.3 VDC.

Digital Output Current

Sinking or Sourcing
I/O 1, 4, 5, 7 outputs 4 mA MAX
I/O 2 and 3 outputs 2 mA MAX
I/O 6 outputs 8 mA MAX

I/O Over-Voltage Protection

Each I/O standard I/O line is protected with by a series over-voltage limiter. Applying voltages greater than 30 volts will permanently damage digital I/O.

Note: Encoder output signals are NOT protected.

External (Secondary) Encoder Maximum Bandwidth

Selectable by Select Encoder Filter (SEF) command. Each level must be held for a minimum of 175nS or 325nS (according to filter selection). Maximum speed is 1 million counts per second.

Analog Inputs

0 to +3.3 VDC input signal range.
10 bit ADC resolution (single).
11 bit ADC resolution (differential).
Analog inputs 1 to 4 are mapped to share digital I/O lines 4 to 7.
Each input has an effective internal 200K ohm impedance to +3.3 VDC.
Analog signals are read every servo cycle (120 μ sec.) and the converted analog data is processed through a 5 ms filter to reduce noise & transients.

Communications

Hardware Interfaces

RS-232, RS-232 multi-drop, or RS-485 multi-drop (software selectable).

Protocols

8-bit ASCII, 9-bit binary, Modbus®, and optional DMX512

Hardware Configuration Settings

Available Baud Rates: 2400, 4800, 9600, 19.2k, 28.8k, 57.6k, 115.2k or 230.4k

Data Bits: 8

Stop Bits: 1.5 or 2

Parity Bit: None

CAN interface

This option is only available with the -J option. (QCI-D2-IG-J)

The CAN bus connection is NOT isolated, but does include transceivers which have an extended +/- 80v fault protection range. The CANopen® communications protocol allows the unit to function as a master, slave, or peer on a CANopen network. See the SilverLode CANopen User Manual for details on the CANopen protocol. This protocol operates simultaneously and independently from the standard serial protocols.

Note that a 120 ohm ½ W termination resistor is needed at each end of the CAN network (only two per system). This termination is not provided onboard the QCI-D2-IG-J(1) controller and must be provided by the user. The QCI-D2-IG-J uses the common power/communications ground as the CAN ground. Do not connect conflicting grounds within the system. No external CAN power is require by the unit.

CANopen® and CiA® are registered community trade marks of CAN in Automation e.V.

Mechanical Specifications

Mechanical (QCI-D2-IG-01)

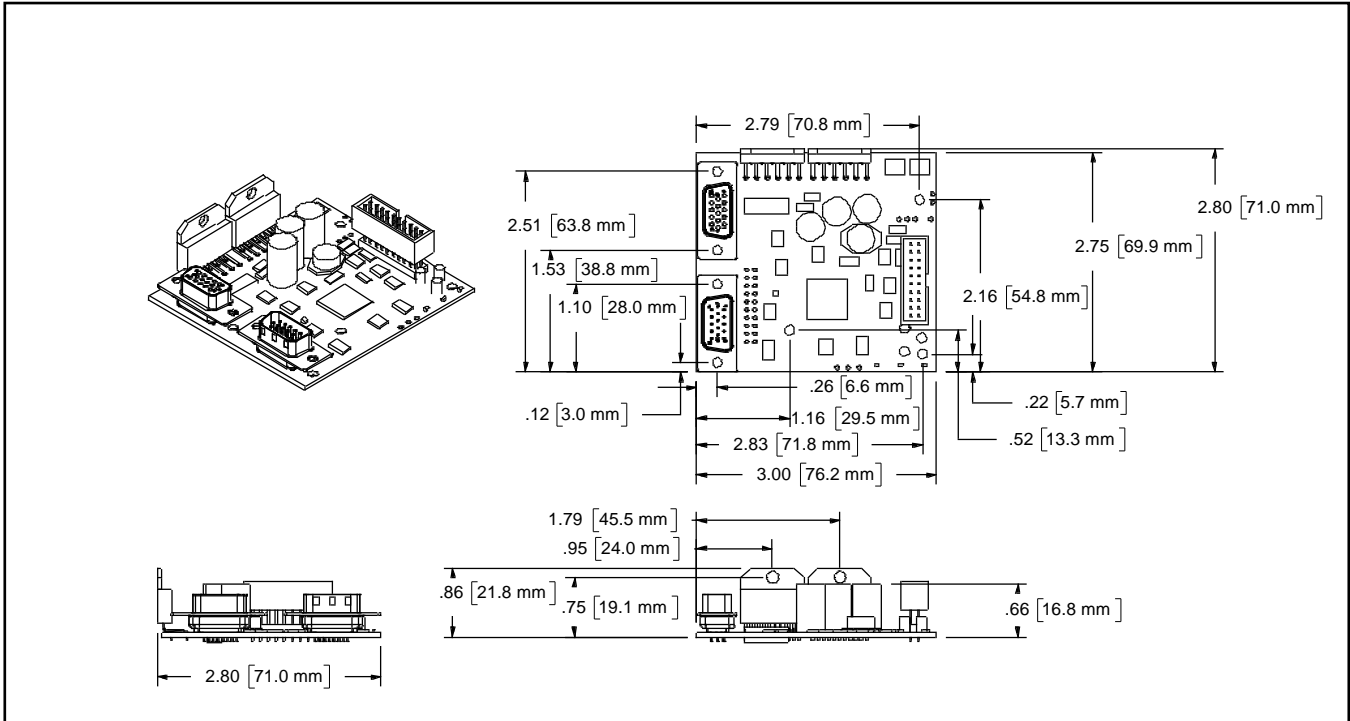

Mechanical (QCI-D2-IG)

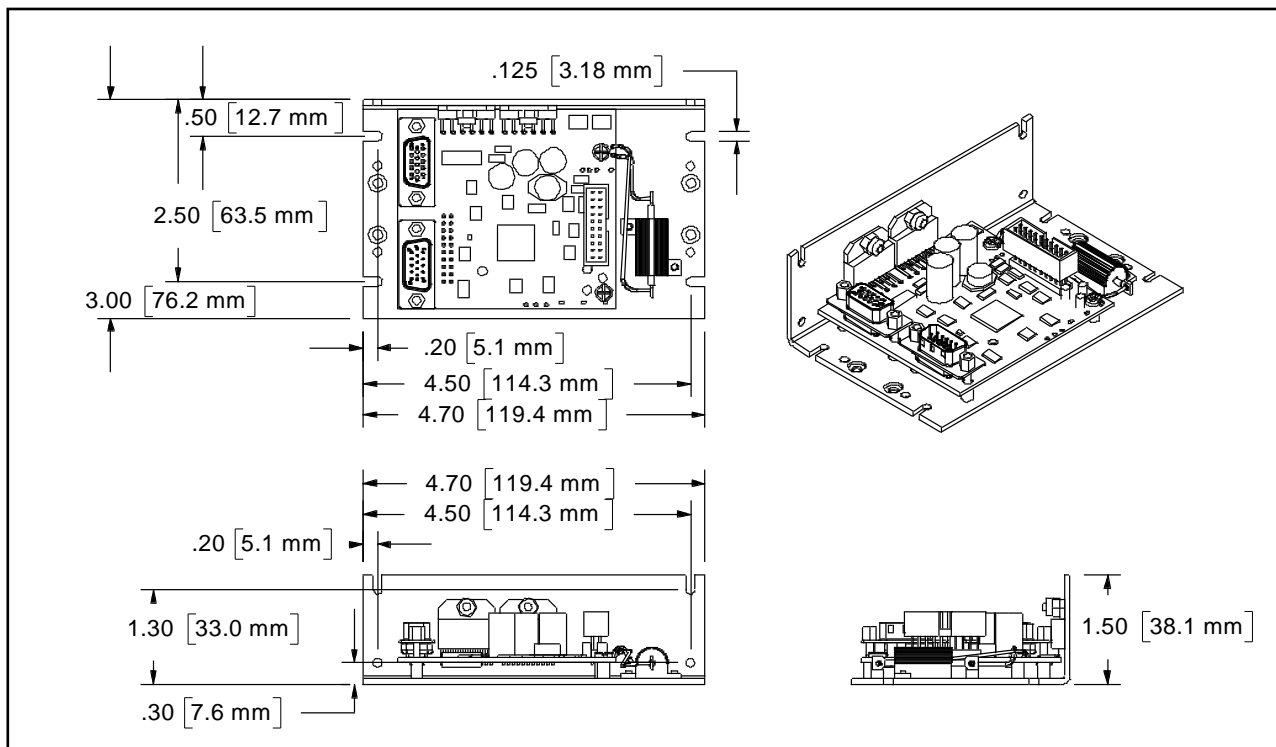

Note: See our website for 2D drawings and 3D models.

Environmental Specifications

Operational Temperature

-10 C to +80 C

Storage Temperature

- 40 C to +85 C

Humidity

Continuous specification is 95% RH non-condensing.

Shock

Limitation is approximately 50g/11ms.

IP Rating

IP20 with cables attached.

Connector Data

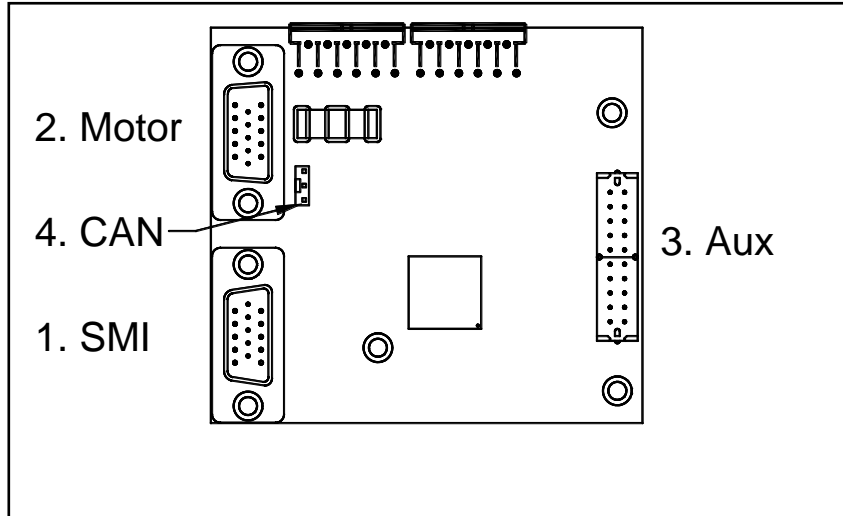

1. SilverLode Multi-function Interface (SMI) Port

This port provides QuickSilver's basic Power, Communication, standard I/O for backward compatibility with our previous systems. All I/O from this port are 0-3.3 Volts. Analog inputs are shared with the digital I/O. Analog inputs have 10-Bits resolution from 0-3.3 Volts. Power inputs are diode OR'ed into power inputs from section 1. Apply power from either side is OK.

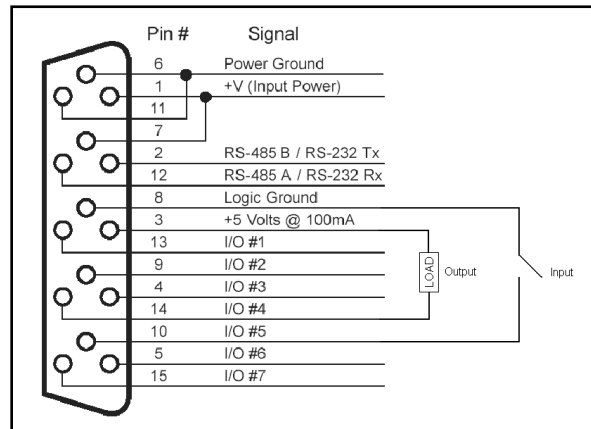

Note: Encoder Inputs on section 5 uses I/O # 4, 5, and 6 listed here. If these I/O are used for electronic gearing, they are **NOT** available for general purpose I/O function.

Note: Communication lines **RS-485A / RS-232 RX**, **RS-485B / RS232 TX**, and **LOGIC GROUND** are all internally connected between the SMI port and the respective pins on the top side connectors. See sections 3, 5, and 6.

2. Motor Interface

QuickSilver recommends our QCI-C-D15P-D15S-nn (nn = length) cable to interface between the motor and the controller.

Note: 01, 02, 04, and 10 feet cables are standard lengths.

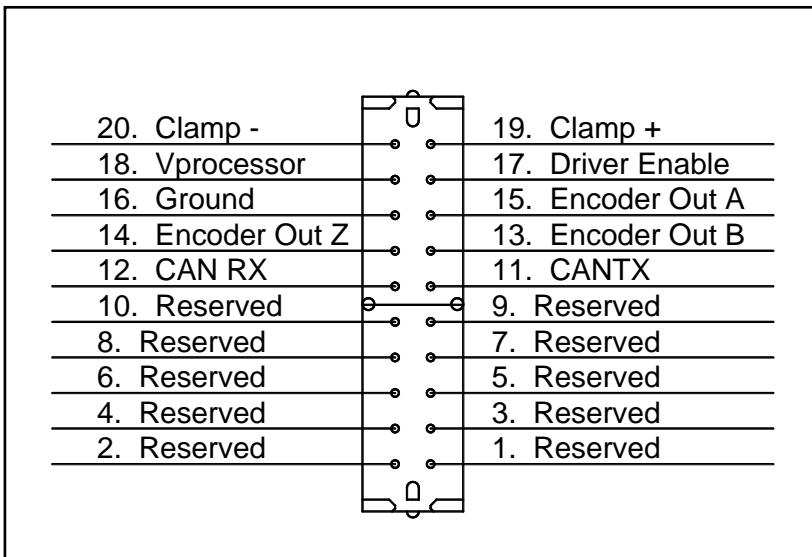
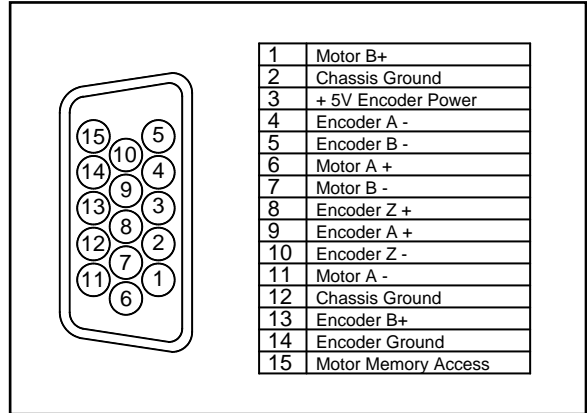

3. Aux

Auxiliary connection.

Driver enable: By default, the SilverDust IG comes with a jumper between pin 17 & 19 to automatically enable the driver. If user applications require a separate hardware drive enable, then use pin 16 and 17 to enable/disable motor driver.

Encoder: For electronic gearing applications that require encoder output from the SilverDust, pins 13, 14, & 15 are quadrature encoder outputs.

Vprocessor: By default, the system power should come from the DB-15 side. The drive/processor power comes from pin 1 & 7 of the DB-15. If the application requires separate processor / drive power, use the pin 16 for Ground and Vprocessor as the processor power.

Note: Do not connect to CAN RX or CAN TX on this connector if using the –J option board.

Connector: The twenty (20) pin auxiliary header is manufactured by Samtec.
Samtec Part #: ZSS-110-03-G-D-740

Mating Connectors:

Samtec: Several options available. Refer to the manufacturer’s website.

3M Part #: 929852-01-10-RA

Ho Chien Part #: 2552-2X10G

4. CAN Interface

This interface is provided on QCI-D2-IG-J and QCI-D2-IG-J1 configurations.

The key to the left provides polarization as well as retention of the connector. The pins provided are Sn (Tin) plated, so the mating connector should also use Sn plated contacts for best reliability.

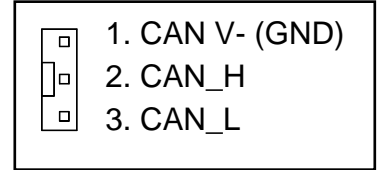

The suggested mating connector and contacts are:

Molex 22-01-3037 (22013037) for the connector body

Molex 08-65-0805 (008650805) Phos-Bronze contacts

or Molex 08-50-0114 (00850114) Brass contacts.

These were stocked at <http://www.alliedelec.com/> as well as other Molex suppliers.

Recommended Components

SilverDust IG Start-Up Kit

For first time users, QCI recommends purchasing the QCI-SKB-D2-IG Start-Up Kit which includes:

- SilverDust D2 IG (QCI-D2-IG) & Datasheet (QCI-DS0019)
- Basic Breakout Module (QCI-BO-B) & Tech Doc (QCI-TD036)
- QuickControl Software CD (QCI-QC)
- User Manual & Command Reference (QCI-SLM)
- Communication Cable (QCI-C-D9M9F-6)
- 4' DB15HD Motor I/F Cable (QCI-C-D15P-D15S-4)
- Start-Up Kit Setup Instructions (QCI-TD040)

With this Start-Up kit, a power supply, and a motor/encoder, you will have everything you need to get started. See technical document QCI-TD040 on our website for details.

The Standard System detailed below uses the QCI-SKB-D2-IG.

SilverDust IG System

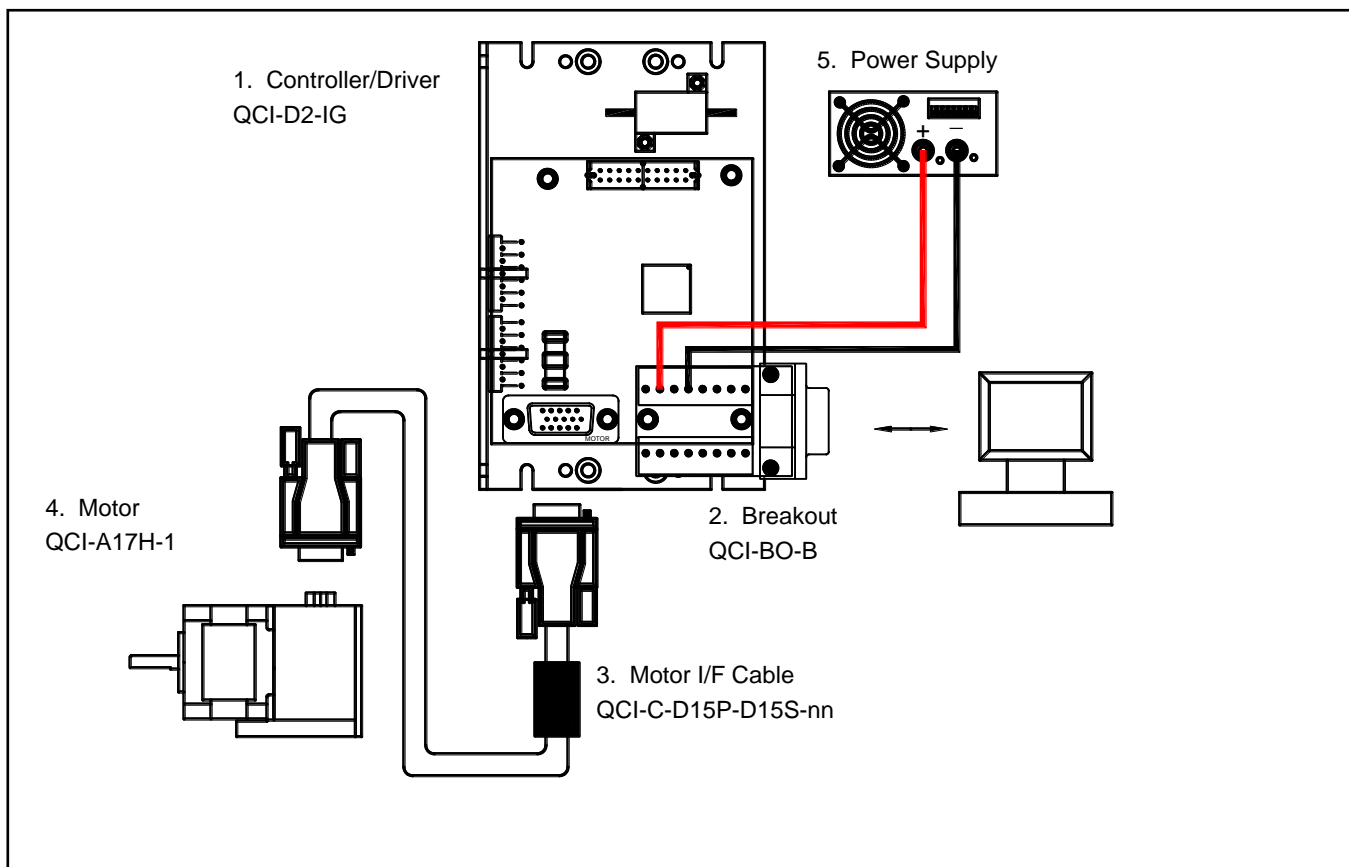

1. Controller/Driver

SilverDust D2 IG (QCI-D2-IG). This is an open frame system without extended I/O. For users that do not need the extra I/O capabilities, this system is recommended for significant cost savings.

2. Basic Breakout (QCI-BO-B or QCI-BO-B52)

QCI recommends purchasing a breakout to simplify wiring power, communications and I/O. QuickSilver offers several breakouts (see our website), but the simplest is our Basic Breakout (QCI-BO-B). To convert the 7 TTL I/O to 5 24V isolated inputs and 2 open collector outputs, select the QCI-BO-B52.

3. Motor I/F Cable

For standard system, this D-sub type cable goes between the motor and the controller. The generic part number is QCI-C-D15P-D15S-nn. Replace the last two digits “nn” with length of cable in feet (i.e. –10 for 10 feet). Standard lengths are 1, 2, 4, and 10 feet.

For IP65 system, a special IP65 cable goes in between the motor and the controller. The motors and cables are IP65, but not the controller/driver. The generic part number is QCI-C-D15P-T14S-nn. Replace the last two digits “nn” with length of cable in feet (i.e. –10 for 10 feet).

4. Motor

The SilverDust D2 is capable of driving any A 17 or 23 I-Grade motor/encoder. See the following datasheets for more information:

QCI-DS007: NEMA 17 I-Grade Motor/Encoder

QCI-DS008: NEMA 23 I-Grade Motor/Encoder

QCI-DS002: NEMA 17 IP65 Motor/Encoder

QCI-DS001: NEMA 23 IP65 Motor/Encoder

See QCI-DS017 for details on using QuickSilver's NEMA 11 frame motor with the IG.

5. Power Supply

Power supply selection is motor dependent, but the following will work with all the 17 and 23 frame motors.

S-210-48 (48V, 4.4A, 210 Watt)

Part Numbers

SilverDust™ IG Controller/Drivers		
DRIVER	CONTROLLER	OPTIONS
<p>QCI-D2 - 3.5 Amp</p> <ul style="list-style-type: none"> • For 23 Frame and Smaller • 3.5 Amps per Phase Continuous* • 4.5 Amp Peak • 4A@12V-48V <p>* Depending on heat sink (25C ambient).</p>	<p>IG – SilverDust D2 IG</p> <ul style="list-style-type: none"> • 7 TTL Inputs or Outputs (use QCI-BO-B52 for 24V I/O) • 4 Analog Inputs (Joystick) • Analog Output Option (use QCI-BO-B1A) • RS-232 or RS-485 • ASCII, Binary, Modbus® • Encoder Output • Voltage Clamp And Resistor • Drive Enable • DB15HD (pin): SMI Port • DB15HD (socket): Motor I/F including motor power and encoder 	<p>Blank – Standard</p> <ul style="list-style-type: none"> • L-Bracket for heat sinking. • DIN compatible <p>01 – Board Only</p> <ul style="list-style-type: none"> • Requires user to properly heat sink. <p>R1 – Board Only</p> <ul style="list-style-type: none"> • Same as 01 w/ Right Angle DB15HD connectors <p>R2– Right-Angle Connector Option</p> <ul style="list-style-type: none"> • L-Bracket for heat sinking • Motor Port with Right-Angle DB15HD connector • SMI Port with Right-Angle DB15HD connector <p>V1 – Board Only</p> <ul style="list-style-type: none"> • Motor Port with Right Angle DB15HD connector • SMI Port with Vertical DB15HD connector <p>V2 – Board Only</p> <ul style="list-style-type: none"> • Motor Port with Vertical DB15HD connector • SMI Port with Right Angle DB15HD connector <p>V3 – Right-Angle Connector Option</p> <ul style="list-style-type: none"> • L-Bracket for heat sinking • Motor Port with Right-Angle DB15HD connector • SMI Port with Vertical DB15HD connector <p>V4 – Right-Angle Connector Option</p> <ul style="list-style-type: none"> • L-Bracket for heat sinking • Motor Port with Vertical DB15HD connector • SMI Port with Right-Angle DB15HD connector <p>D – DMX512</p> <p>J – CANopen®</p> <ul style="list-style-type: none"> • L-Bracket for heat sink • CAN connector <p>J1 – CANopen® Board only</p> <ul style="list-style-type: none"> • Same as 01, but with CANopen option.
For an IG with board only		

QCI-D2	IG	01
This selection creates the part number: QCI-D2-IG-01		

Example Part Numbers:

- QCI-D2-IG
- QCI-D2-IG-01
- QCI-D2-IG-R1
- QCI-D2-IG-V1
- QCI-D2-IG-J
- QCI-D2-IG-J1

New Part Numbers

The part numbers have been revised

Description	Old Part Number	New Part Number
SilverDust IG Open Frame Servo Controller with L-Bracket	D2-G1-02-IG	QCI-D2-IG
SilverDust IG Open Frame Servo Controller without L-Bracket	D2-G1-01-IG	QCI-D2-IG-01
SilverDust IG Open Frame Servo Controller without L-Bracket Right angle D15HD connectors	D2-G1-R1-IG	QCI-D2-IG-R1

NOTE: If old part numbers are ordered, they are shipped with firmware revision 17.
Revision 17 does not include multi-threading.

Contact Information

QuickSilver Controls, Inc.
 990 N Amelia Ave
 San Dimas, CA 91773
 909-599-6291 or (888) 660-3801
 909-599-6289 FAX
www.QuicksilverControls.com